

EN | HUSKY, BASSET, HBK

Belt sanders, Oscillating edge sander

**Reliability, stability  
and excellent precision**

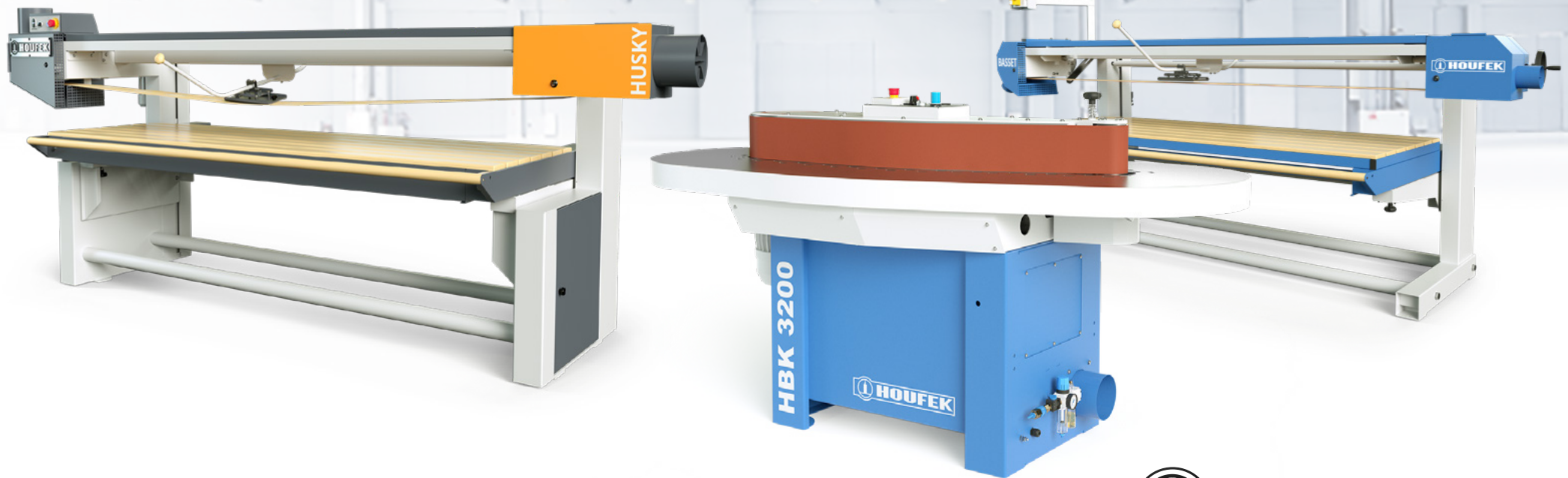



Husky series

## Maximum performance and precision with belt sanders HUSKY

2200 / 2500 / 3000

Husky is belt sander based on Basset series. The parameters and robust construction make it the belt sander of the highest class of the production program of HOUFEK. Belt sander HUSKY is designed for sanding wooden workpieces or wood base composite materials, and some plastic materials.

Considering the features the belt sander HUSKY is designed for small and medium workshops.

### → Introduction

Standard and Optional equipment

Technical Specifications

Houfek machines



## Features

- Sanding the flat desks and parts
- Work table length up to **3000 mm**
- Motor power up to **3 kW**
- Electric desk lift up to **420 mm**

## Applications

- Sanding the flat desks and parts placed on height adjustable worktop using the support ruler system preventing the part shifting
- Husky belt sander is suitable for small and medium woodworking facilities

## STANDARD AND OPTIONAL EQUIPMENT

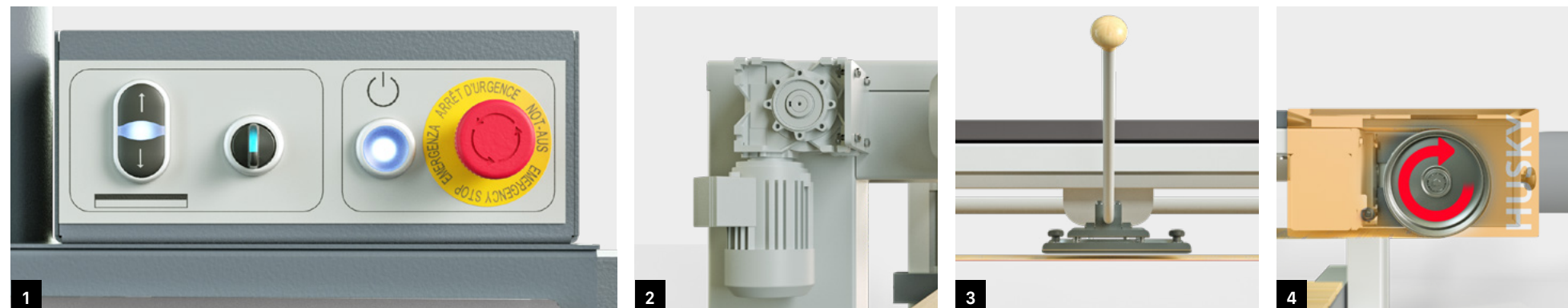

### Standard equipment

- Motorized table height adjustment
- Motor 3 kW, 1440 RPM, 17 m/s
- Work table dimension 800 x 2200, 800 x 2500, 800 x 3000 mm
- Table lift 420 mm
- Table horizontal movement 700mm
- Sanding belt 150 x 6200 mm, 150 x 6800 mm, 150 x 7800 mm
- Sanding belt speed 17m/s
- Exhaust hoods on both sides Ø 2 x 180 mm
- CE certification

### Optional equipment

- Motor 4 kW (5,5 HP)
- Two speed motor 14, 28 m/s
- Table vertical stroke 750 mm
- Reverse belt direction
- Sanding belt motor frequency inverter - speed 4,5 - 27 m/s
- Phase monitor relay
- Table lighting
- Additional dust extraction hood Ø 100 mm
- Diameter of rollers 300 mm
- Modification for closed frame sanding

## TECHNICAL SPECIFICATIONS

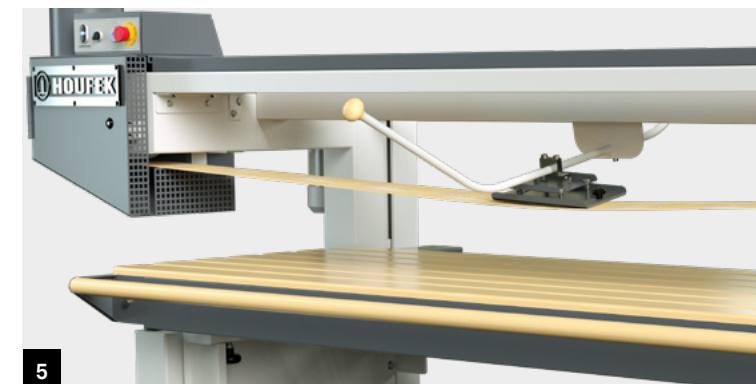

### HUSKY BELT SANDER

		2200	2500	3000
Sanding belt dimensions (L x W)	mm	6200 x 150	6800 x 150	7800 x 150
Sanding belt speed	m/s	17	17	17
Max. working width	mm	2200	2500	3000
Table horizontal travel	mm	700	700	700
Max. workpiece weight	kg	100	100	100
Motor	kW	3	3	3
Machine dimensions (L x W x H)	mm	3330 x 1240 x 1495	3630 x 1240 x 1495	4130 x 1240 x 1495
Weight	kg	600	605	645

1. CONTROL PANEL
2. ELECTRIC DESK LIFT
3. SANDING PAD
4. SANDING BELT REVERSE OPERATION
5. WORK TABLE

BELT SANDER  
**HUSKY**

Introduction

→ **Standard and Optional equipment**

→ **Technical Specifications**

Houfek machines





Basset series

## Simple and verified construction

1000 / 2200 / 2500 / 3000

Classic belt sander based on the series Eco. It is designed for sanding wooden workpieces or wood base composite materials, and some plastic materials. The machine can be completed with a range of specific accessories, and in comparison with Eco series, Basset enables the machining of larger parts.

Considering these features, the belt sander BASSET is designed in small and medium workshops.

### → Introduction

Standard and Optional equipment

Technical Specifications

Houfek machines

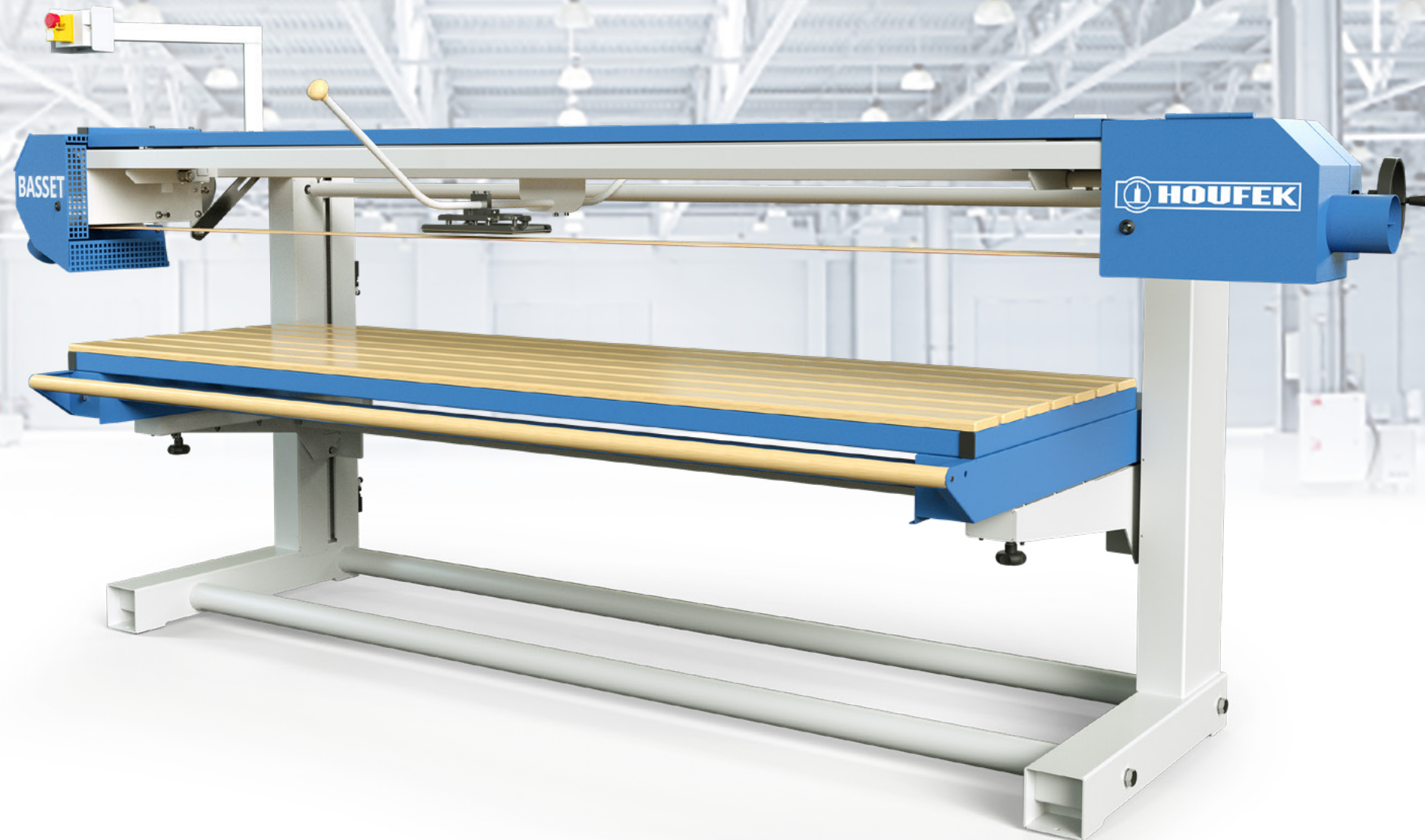

## Features

- Sanding the flat desks and parts
- Work table length up to **3000 mm**
- Motor power up to **3 kW**
- Working unit rotation **90 °**

## Applications

- Sanding the flat desks and parts placed on height adjustable worktop using the support ruler system preventing the part shifting
- Husky belt sander is suitable for small and medium woodworking facilities

# STANDARD AND OPTIONAL EQUIPMENT



1

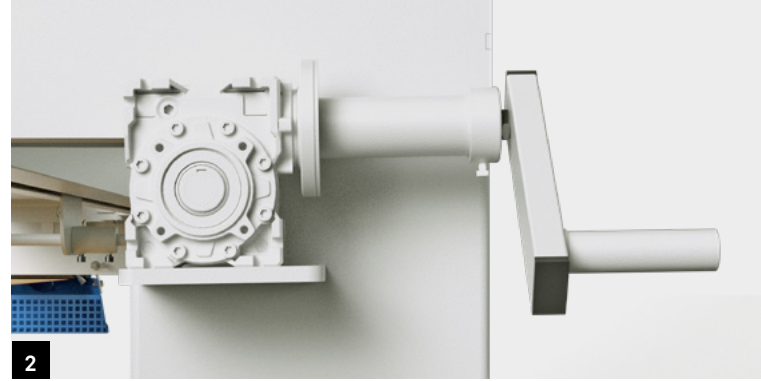

2

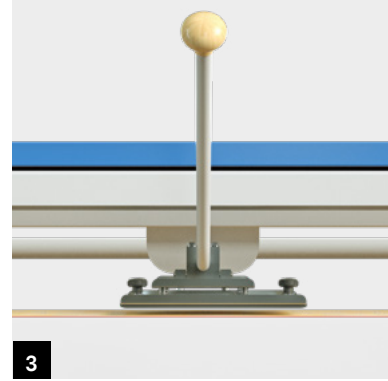

3

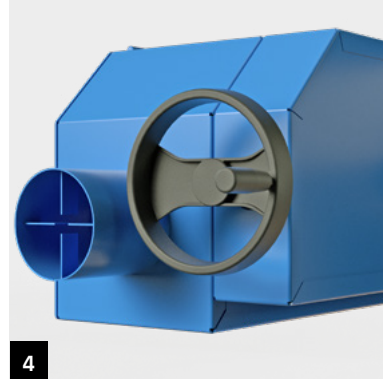

4

## Standard equipment

- Manual table height adjustment, vertical stroke 540 mm
- Motor 3 kW, 17 m/s
- Exhaust hood on both sides Ø 2 x 100 mm
- Tilttable sanding head
- Table horizontal movement 700 mm
- Work table dimension 800 x 1000, 800 x 2200, 800x 2500, 800 x 3000 mm
- Sanding belt size 150 x 4000, 150 x 6400, 150 x 7000, 150 x 8000 mm sanding belt
- CE certification

## Optional equipment

- 1 phase, 230 / 50Hz, motor 2,2 kW
- Two speed motor 14, 28 m/s
- Motorized table lift
- Reverse belt direction
- Sanding belt motor frequency inverter - speed 4,5 - 27 m/s
- Phase monitor relay
- Table lighting
- Table vertical stroke 750 mm
- Longitudinal table tilting
- Modification for closed frame sanding

# TECHNICAL SPECIFICATIONS

BELT SANDER  
**BASSET**



5

## BASSET BELT SANDER

		1000	2200	2500	3000
Sanding belt dimensions (L x W)	mm	4000 x 150	6400 x 150	7000 x 150	8000 x 150
Sanding belt speed	m/s	17	17	17	17
Tilttable sanding unit	°	90	90	90	90
Max. working dimensions (L x W)	mm	1000 x 800	2200 x 800	2500 x 800	3000 x 800
Horizontal and vertical table travel	mm	700 x 540	700 x 540	700 x 540	700 x 540
Max. workpiece weight	kg	100	100	100	100
Motor	kW	3	3	3	3
Machine dimensions (L x W x H)	mm	2200 x 1300 x 1700	3400 x 1300 x 1700	3700 x 1300 x 1700	4200 x 1300 x 1700
Weight	kg	490	504	516	530

1. CONTROL PANEL
2. MANUAL DESK LIFT
3. SANDING PAD
4. BELT TENSION
5. WORK TABLE

Introduction

→ **Standard and Optional equipment**

→ **Technical Specifications**

Houfek machines





HBK

## Practical and reliable edge sander HBK

3200

HBK 3200 completes the series of edge oscillation sanders with wide scope of use. High performance machine with specially adjusted sanding unit is suitable in particular for sanding the curve edges.

The miller is applied for the staircase producing.

### → Introduction

[Standard and Optional equipment](#)

[Technical Specifications](#)

[Houfek machines](#)

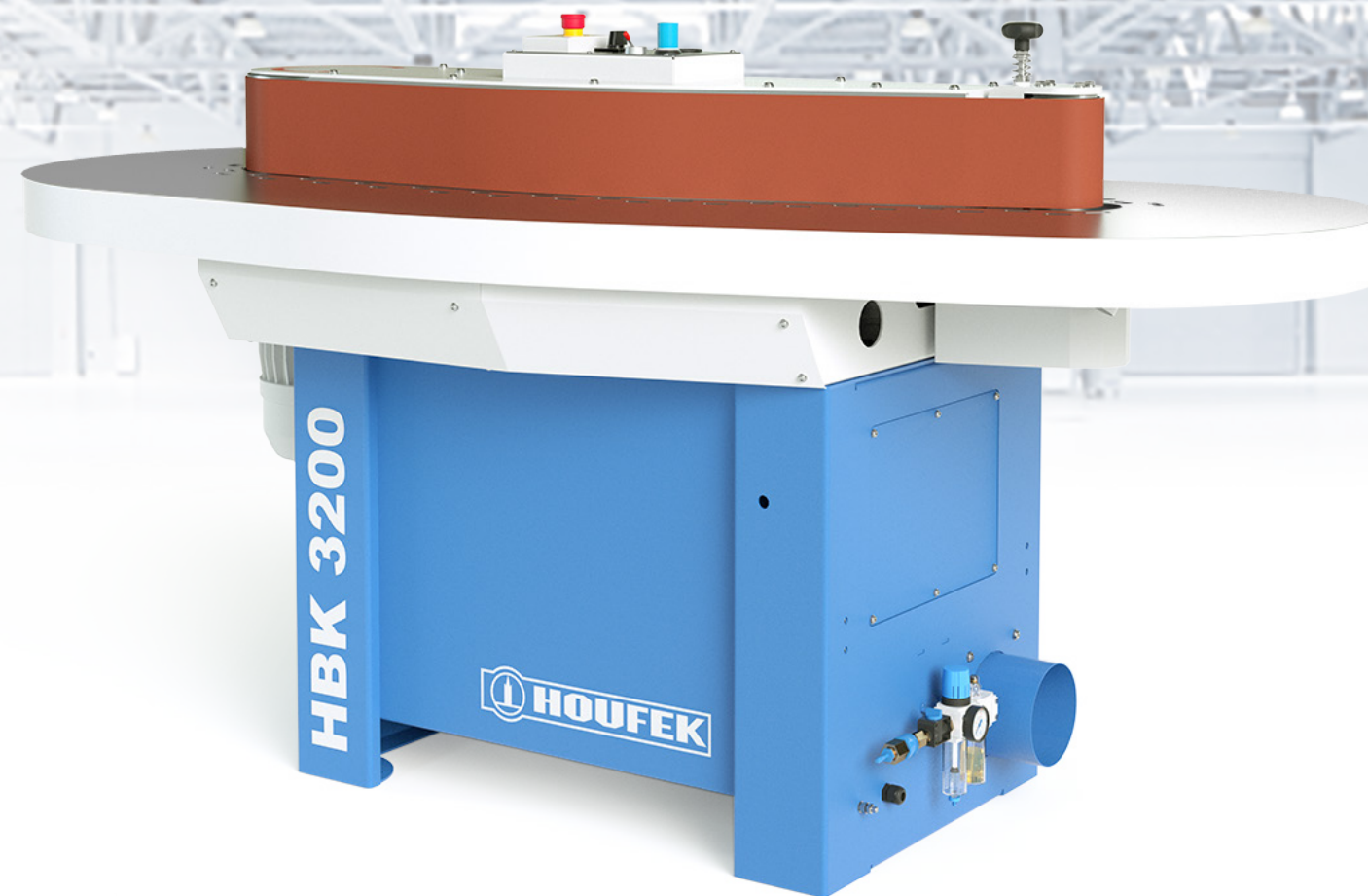

## Features

- Sanding flat and bent edges
- Work table length up to **1000 mm**
- Motor power up to **3 kW**
- Pneumatic belt stretching

## Applications

- Sanding round and radius edges and surfaces of parts placed on the worktable
- HBK belt sander is suitable for staircase producing facilities

## STANDARD AND OPTIONAL EQUIPMENT

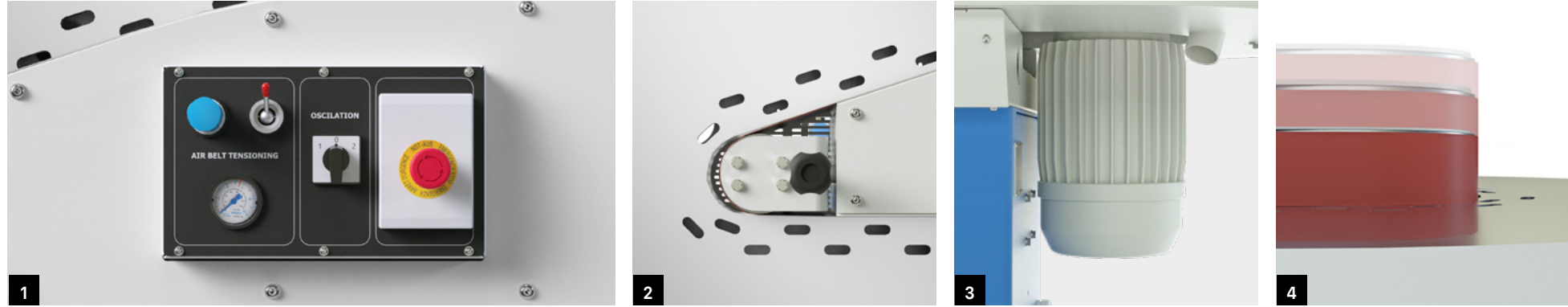

### Standard equipment

- Sanding belt size 150 mm x 3200 mm
- Motor 3 kW, 950 RPM, 15 m/s
- Height adjustable sanding unit
- Pneumatic sanding belt tensioning
- Oscillating sanding unit
- Work table length 2180 mm
- Work table width 1030 mm
- Exhausting in table, exhaust outlet Ø 150 mm

### Optional equipment

- Motor 4 kW (5,5 HP)
- Motor with brake
- Sanding belt motor frequency inverter - speed 6 - 17m/s
- Motorized sanding unit height adjustment
- Rubbered drive roller
- Supporting ruler for sanding against the rubbered roller
- Mitre fence
- Exhaust hood with magnetic tips
- Modification for power feed unit
- Carriage with 4 wheels

## TECHNICAL SPECIFICATIONS

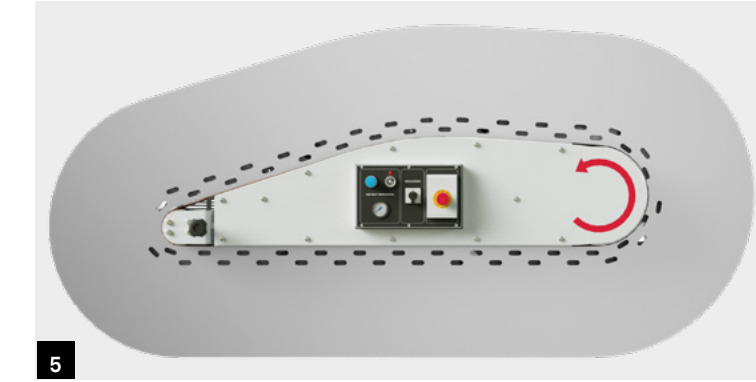

### HBK OSCILLATING EDGE SANDER

3200

Sanding belt dimensions (L x W)	mm	3200 x 150
Sanding belt speed	m/s	15
Max. working dimensions (L x W)	mm	2180 x 1015
Exhaust outlet diameter	mm	150
Motor	kW	3
Machine dimensions (L x W x H)	mm	2180 x 1015 x 1065
Weight	kg	565

1. CONTROL PANEL
2. BELT TENSION
3. MOTOR
4. HEIGHT ADJUSTABLE SANDING UNIT
5. WORK TABLE

OSCILLATING EDGE SANDER

**HBK**

Introduction

→ **Standard and Optional equipment**

→ **Technical Specifications**

Houfek machines





# Houfek machines

## Woodworking machines

Woodworking machines Houfek were made with regard to simple construction, maximum performance and good price.

Construction materials and components used for production are together with the technical machine solution a guarantee of reliable, easy and safe machine operation, high quality of machining and economical operation.

[Introduction](#)

[Standard and Optional equipment](#)

[Technical Specifications](#)

→ **Houfek machines**



### Wide belt sanders

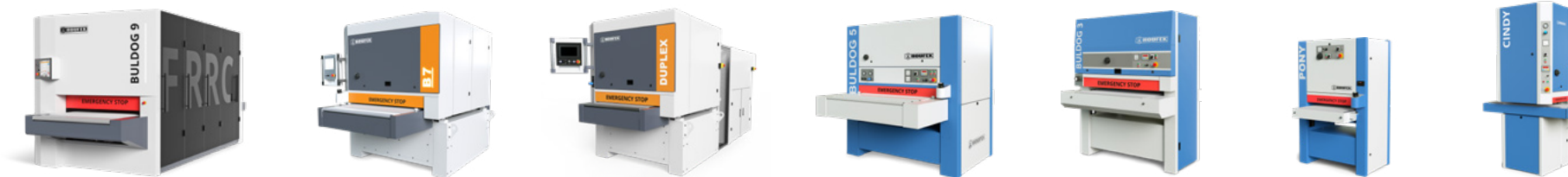

### Surface planers and thicknessers



### Brushing machines



### Belt sanders and oscillating edge sanders







**We export to 45 countries  
worldwide.  
Our machines run also  
in overseas states.**



**Houfek a.s.  
Obora 797  
582 82 Golčův Jeníkov  
Czech Republic**



+420 569 430 700  
+420 737 243 917  
+420 737 243 911



export@houfek.com



www.houfek.com



EUROPEAN UNION  
European Regional Development Fund  
Operational Programme Enterprise  
and Innovations for Competitiveness

